

Add-on/Spare Tape Magazine Instructions

This document describes how to remove and replace a tape magazine in a NEO XL-Series library from Overland Storage.

WARNING: To reduce the risk of electric shock or damage to equipment, always remove any power cords while working with the unit.

WARNUNG: Um das Risiko eines elektrischen Schlags oder Schäden am Gerät zu vermeiden, ziehen Sie stets den Netzstecker, bevor Sie an der Einheit arbeiten.

AVERTISSEMENT: Pour réduire le risque de choc électrique ou endommagement de l'équipement, retirez toujours les cordons électriques en travaillant avec l'appareil.

CAUTION: While working with the unit, observe standard Electrostatic Discharge (ESD) precautions to prevent damage to micro-circuitry or static-sensitive devices.



Install/Replace the Tape Magazine

Unlock the Magazine

Unlock the magazine using the OCP or RMI. If these methods fail, or if a magazine needs to be removed when the power to the device is off, you can release the magazine manually. Only one magazine or mailslot can be open at a time.

NOTE: As a best practice, perform this procedure while applications are idle. While the magazine is extended, the library robotic assembly cannot move media.

1. Open the **magazine access door**.
2. Log in as an administrator in **OCP** or **RMI**.
3. On the **Home** screen, tap **Open Magazine**.
4. Tap or select **Unlock** in the left or right magazine column within the module containing the magazine to be replaced.
5. Tap or select **Open**.

A message box indicates when the magazine has been unlocked.

The **Open Magazine** screen shows that the magazine is now unlocked.

NOTE: If not removed, the magazine and the mailslot will relock after 30 seconds.

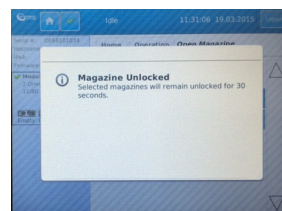

Manually Release Magazine

NOTE: To simply install a new magazine, proceed to *Install the Magazine*.

1. Insert a small flat head screwdriver or Torx driver into the **appropriate magazine release hole** and gently push the tab in.

CAUTION: Do not exert force once you encounter resistance. Doing so can damage the device.

2. Slowly **pull the magazine** free of the latch.
3. Remove the **tape cartridges**, noting their locations within the magazine.

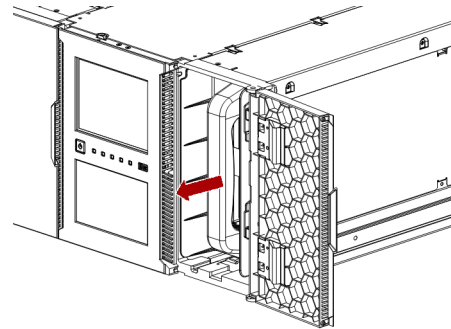
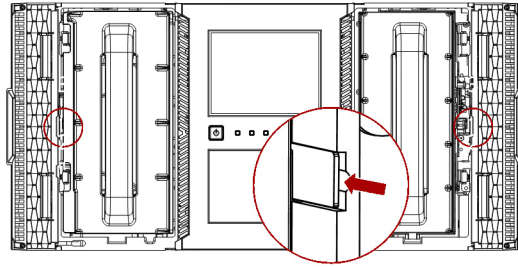

Remove the Magazine

1. Push the magazine approximately 12 mm (0.5 inches) **back into the module** to remove the tension from the release mechanism.
2. While pushing the two red latches toward the front of the rack, on the back side of the magazine, **slide the magazine** until it clears the release mechanism.
3. While supporting the bottom of the module, use one hand to completely **remove the magazine** from the module.

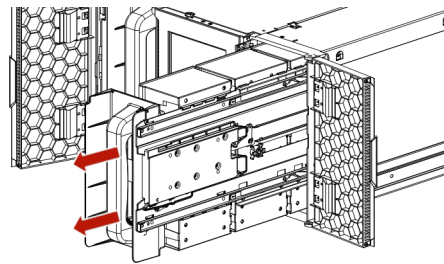
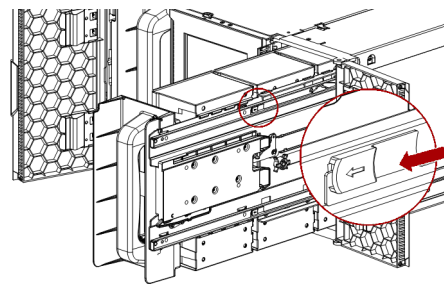

Install the Magazine

1. Position the upper and lower **magazine rails** onto the **alignment rails**.
2. Push in slowly until the **magazine rails** are properly seated and the magazine is only slightly extended.
NOTE: Stop before locking the magazine.
3. Pull the **magazine** back out until fully extended.
4. Load the **tape cartridges** into the new magazine in the same location they were in previously.
5. Push the **magazine handle** slowly until the magazine release latch snaps into place. The magazine locks into place after it is correctly installed.

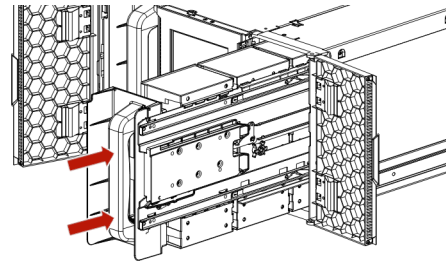

Verifying the Magazine Installation and Operation

1. Using the OCP or RMI:
 - Verify that the **replaced magazine** is closed.
 - Verify that the **cartridges** in the replaced magazine are inventoried.
2. If you replaced the **right-side magazine**:
 - Verify that the **cartridges** in the mailslot are inventoried.
 - Unlock the **mailslot** using the OCP or RMI, pull it out, and push it back in.

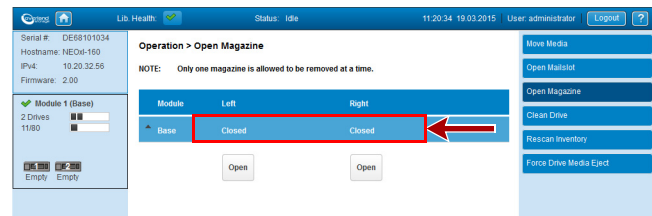

Return Old Parts to Overland

1. Place the **old part** in the anti-static bag and put it in the replacement part's box.
2. Use the existing **packing material** to secure it in the box.
3. Use an RMA to return the part to **Overland Storage**.
For return shipping details and RMA number, go to: <http://docs.overlandstorage.com/return-instructions>.

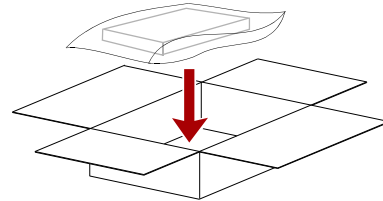

<http://support.overlandstorage.com>

You can get additional technical support on the Internet at the [Overland Storage Support web page](http://support.overlandstorage.com), or by contacting Overland Storage using the information found on the [Contact Us](#) page on our web site.